

SC-75A: 3-LEADS

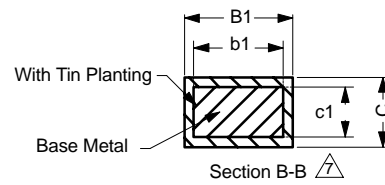
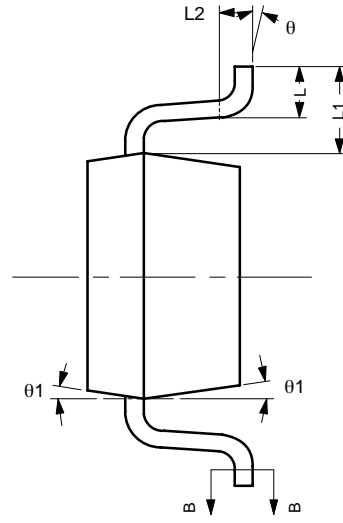
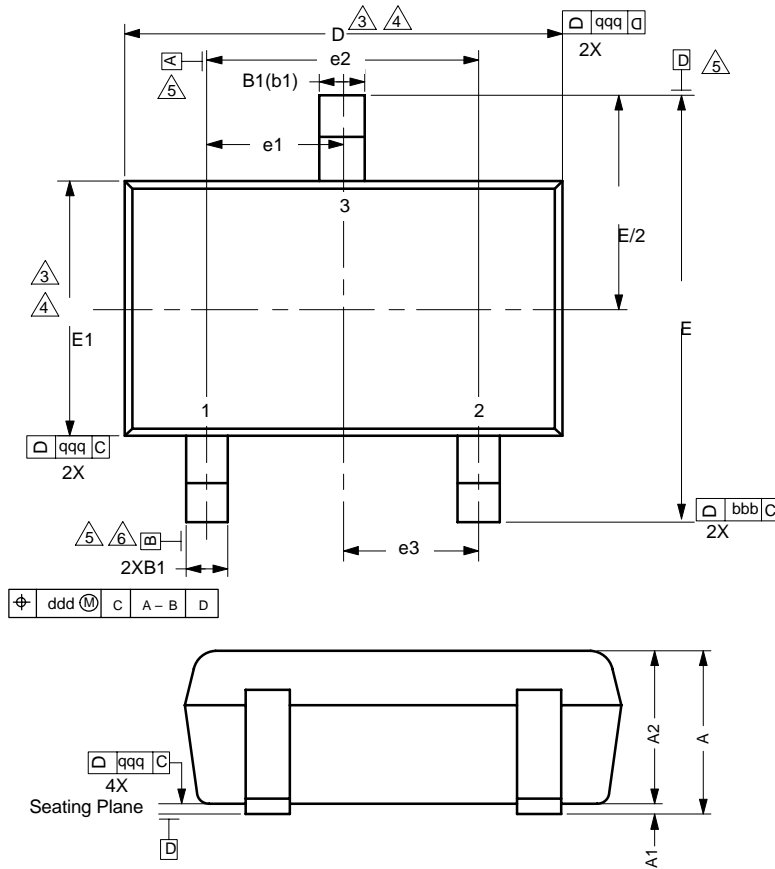

NOTES:

Dimensions in Millimeters.

- 3. Dimension D does not include mold flash, protrusions or gate burrs. Mold flash protrusions or gate burrs shall not exceed 0.10 mm per end. Dimension E1 does not include Interlead flash or protrusion. Interlead flash or protrusion shall not exceed 0.10 mm per side.
- 4. Dimensions D and E1 are determined at the outmost extremes of the plastic body exclusive of mold flash, tie bar burrs, gate burrs and interlead flash, but including any mismatch between the top and bottom of the plastic body.
- 5. Datums A, B and D to be determined 0.10 mm from the lead tip.
- 6. Terminal positions are shown for reference only.
- 7. These dimensions apply to the flat section of the lead between 0.08 mm and 0.15 mm from the lead tip.

Dim	Tolerances
aaa	0.10
bbb	0.10
ccc	0.10
ddd	0.10

Dim	MILLIMETERS			Note
	Min	Nom	Max	
A	-	-	0.80	
A ₁	0.00	-	0.10	
A ₂	0.65	0.70	0.80	
B ₁	0.19	-	0.24	7
b ₁	0.17	-	0.21	
c	0.13	-	0.15	7
c ₁	0.10	-	0.12	7
D	1.55	1.575	1.60	3,4
E	1.50	1.60	1.70	
E ₁	0.73	0.76	0.80	3,4
e ₁	0.50 BSC			
e ₂	1.00 BSC			
e ₃	0.50 BSC			
L	0.15	0.205	0.30	
L ₁	0.40 REF			
L ₂	0.15 BSC			
θ	0°	-	8°	
θ ₁	4°	-	10°	

ECN: S-03946-Rev. B, 09-Jul-01
DWG: 5868